

Preparation unit—G Series

GL Series Lubricator



Symbol



Product feature

1. The structure of oil dripping adopts gap seal type, which makes the adjustment of oil supply more reliable.
2. Oil feed ring can only make one full turn. The quantity of oil supply basically takes on linear distribution. The quantity of oil supply can be generally calculated according to the position of graduation ring.
3. Special drip nozzle structure will produce negative pressure in oil dripping outlet and the mist flow is minimal.
4. Filling of oil while the lubricator is under pressure is made possible, and the oil bowl is large;
5. The bracket can be selected for installation.

Specification

Model	GL200-06	GL200-08	GL300-08	GL300-10	GL300-15	GL400-10	GL400-15	GL600-20	GL600-25
Fluid	Air								
Port size [Note1]	1/8"	1/4"	1/4"	3/8"	1/2"	3/8"	1/2"	3/4"	1"
Pressure range	0.05~1.0MPa(7~145psi)								
Proof pressure	1.5MPa(215psi)								
Temperature range	-5~70°C(Unfreeze)								
Recommended lubricant	ISO VG32or equivalent								
Capacity of oil bowl	25CC		75CC			160CC		380CC	
Weight	130g		360g			670g		1300g	

[Note1] PT thread, G thread and NPT thread are available.

Ordering code

GL200 08 □ G



① Model	② Port size	③ Accessories	④ Thread type
GL200: G200 Series Lubricator	06: 1/8" 08: 1/4"	Blank: Bracket J: No bracket(standard configuration)	Blank: PT G: G T: NPT
GL300: G300 Series Lubricator	08: 1/4" 10: 3/8" 15: 1/2"		
GL400: G400 Series Lubricator	10: 3/8" 15: 1/2"		
GL600: G600 Series Lubricator	20: 3/4" 25: 1"		

Inner structure

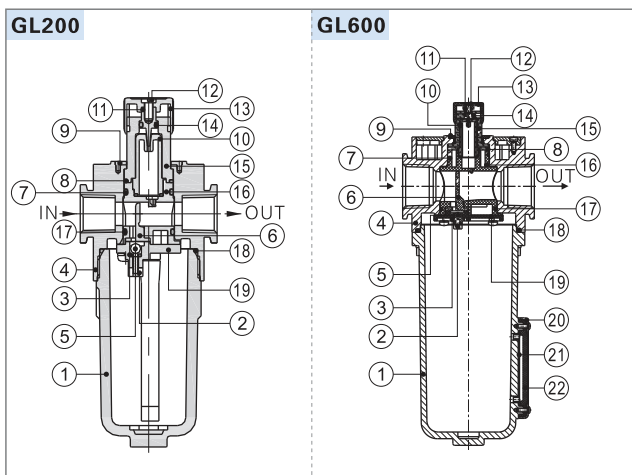

No.	Item	Material	No.	Item	Material
1	Oil bowl	Aluminum alloy (GL600)\PC(others)	12	Screw	Carbon steel
2	Adjusting spring	Stainless steel	13	Adjusting ring	POM
3	O-ring	NBR	14	O-ring	NBR
4	Body of	Aluminum alloy	15	Bowl	PC
5	Steel ball	Stainless steel	16	Sprayer body	PA66
6	Distance block	TPU	17	O-ring	NBR
7	O-ring	NBR	18	O-ring	NBR
8	O-ring	NBR	19	Sprayer bottom cap	POM
9	Indicating ring	POM	20	Liquid meter cover	SPCC
10	Drip pipe	PC	21	Liquid meter seal	NBR
11	Ejector pin	Brass	22	Liquid meter inside cover	PC



Preparation unit—G Series

GL Series Lubricator

Flow chart

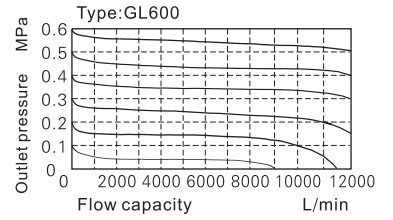
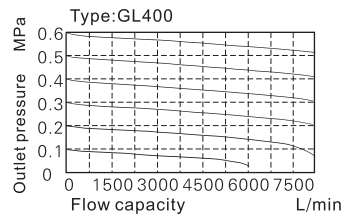
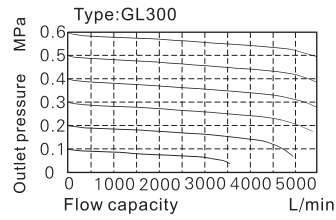
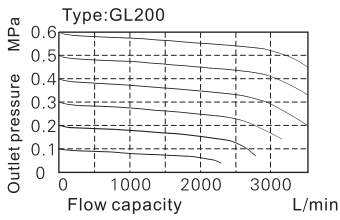

Dimensions

GL200

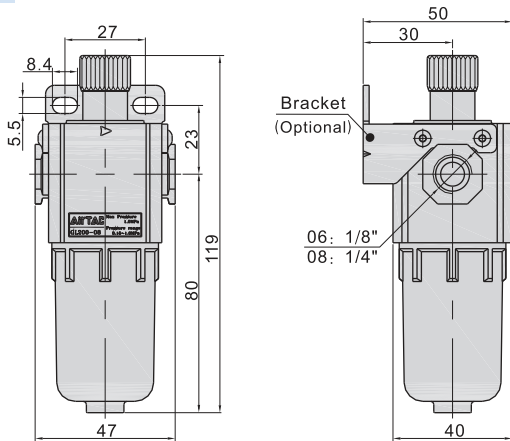

GL300\GL400

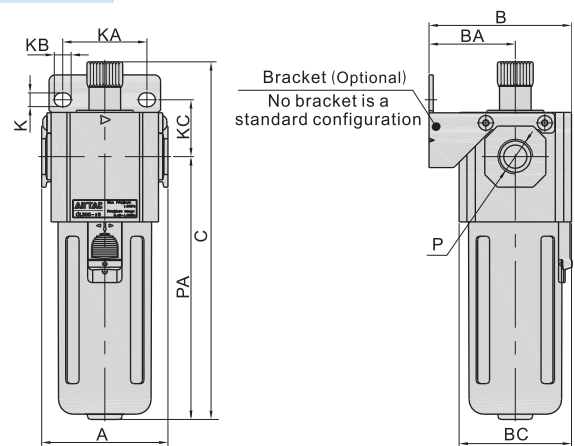

GL600

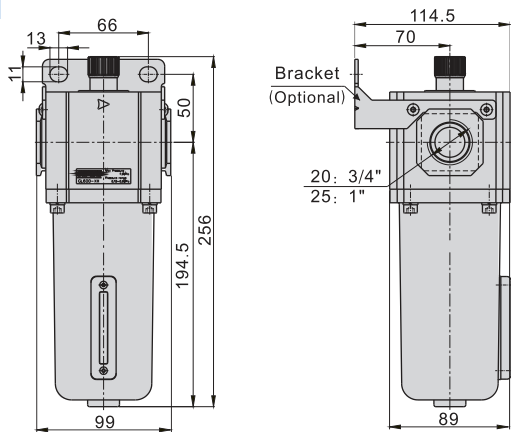

Model\Item	A	B	BA	BC	C	K	KA	KB	KC	P	PA
GL300-08	60	68	41	53.5	169	6.5	40	8	27	1/4"	125
GL300-10	60	68	41	53.5	169	6.5	40	8	27	3/8"	125
GL300-15	60	68	41	53.5	169	6.5	40	8	27	1/2"	125
GL400-10	80	85.5	50	71	190	8.5	55	11	33.5	3/8"	142
GL400-15	80	85.5	50	71	190	8.5	55	11	33.5	1/2"	142